

CARGOMASTER DATA QUESTIONNAIRE - Page 1 of 4
PLEASE RETURN THIS SHEET COMPLETED WITH THE WAYNE ORDER FORM

Your order cannot be processed with out this information.

SOLD TO:

END USER:

Name: _____ Name: _____

Address: _____ Address: _____

City: _____ STATE: _____ ZIP _____ City: _____ STATE: _____ ZIP _____

Contact: _____ Contact: _____

Phone: _____ Phone: _____

FAX: _____ FAX: _____

Purchase Order Number: _____ WAYNE Control Number: _____

TRAILER OR STRAIGHT TRUCK BODY INFORMATION

MANUFACTURER: _____ PHONE NO: _____

ENGINEERING CONTACT: _____ FAX: _____

MODEL: _____ VIN: _____ MONTH/YEAR ____/____

TYPE: _____ TRAILER _____ STRAIGHT TRUCK VOLTAGE: _____ 12V _____ 24V

SIDE DOORS: _____ YES _____ NO IF YES QUANTITY: _____ LEFT (DRIVERS SIDE) _____ RIGHT (CURB SIDE)

REAR DOORS: _____ SWING _____ ROLL UP

CARGOMASTER DATA QUESTIONNAIRE - Page 2 of 4

REAR DOOR FRAME DIMENSIONS:

- A _____ DIMENSION BETWEEN DOOR POSTS
If roll up door minimum dimension between tracks
- A2 _____ DIMENSION BETWEEN DOOR REINFORCEMENT
OR IF OPEN TOP THE NARROWEST INSIDE
DIMENSION
- B _____ UNDERSIDE OF DOOR HEADER TO FLOOR
Or fully raised roll up door which ever is less.
- B2 _____ UNDERSIDE OF DOOR REINFORCEMENT TO
FLOOR
- C _____ MINIMUM INTERIOR HEIGHT

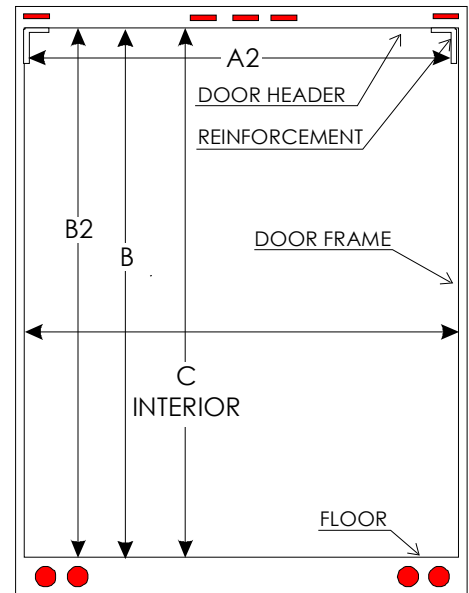

INTERIOR LAYOUT

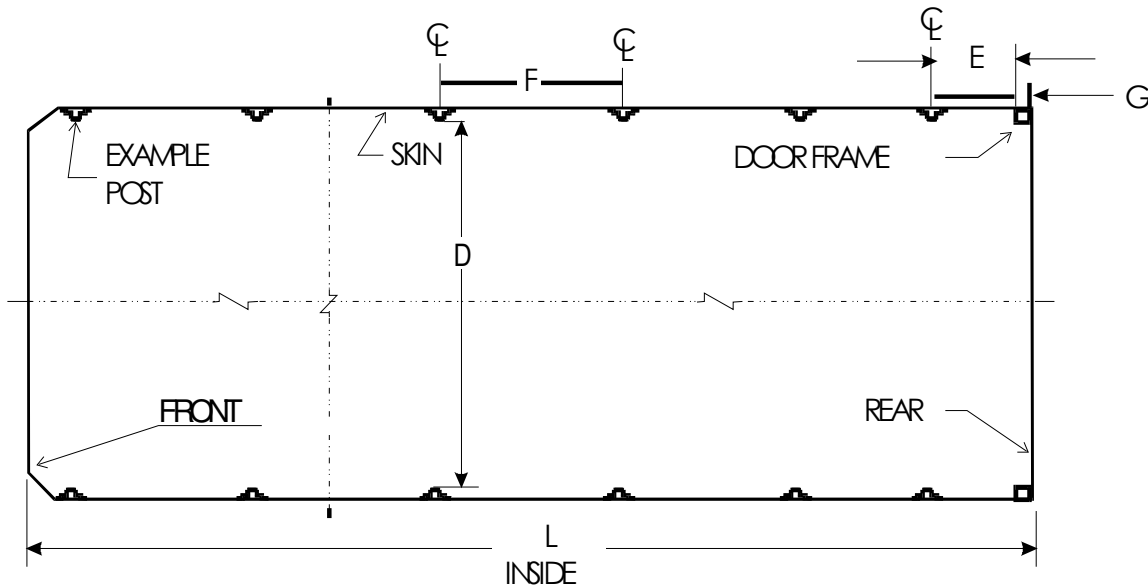

- | | | | |
|----------|---|---------|---|
| D _____ | DIMENSION BETWEEN FACE OF POSTS | F _____ | DIMENSION BETWEEN CENTERLINE OF POSTS. If post centers vary more than 4" list center lines on a separate sheet. |
| E _____ | DIMENSION BETWEEN INSIDE OF DOOR POST TO CENTERLINE OF FIRST POST | G _____ | DIMENSION OF REAR POST |
| F2 _____ | NUMBER OF POSTS | H _____ | TRAILER INSIDE LENGTH |

CARGOMASTER INSTALLATION DATA QUESTIONNAIRE - Page 3 of 4

POST CROSS-SECTION

RECORD ALL APPLICABLE DIMENSIONS - SUPPLY MANUFACTURE'S POST DATA SHEET

Failure to supply manufacturers post data sheet may delay processing

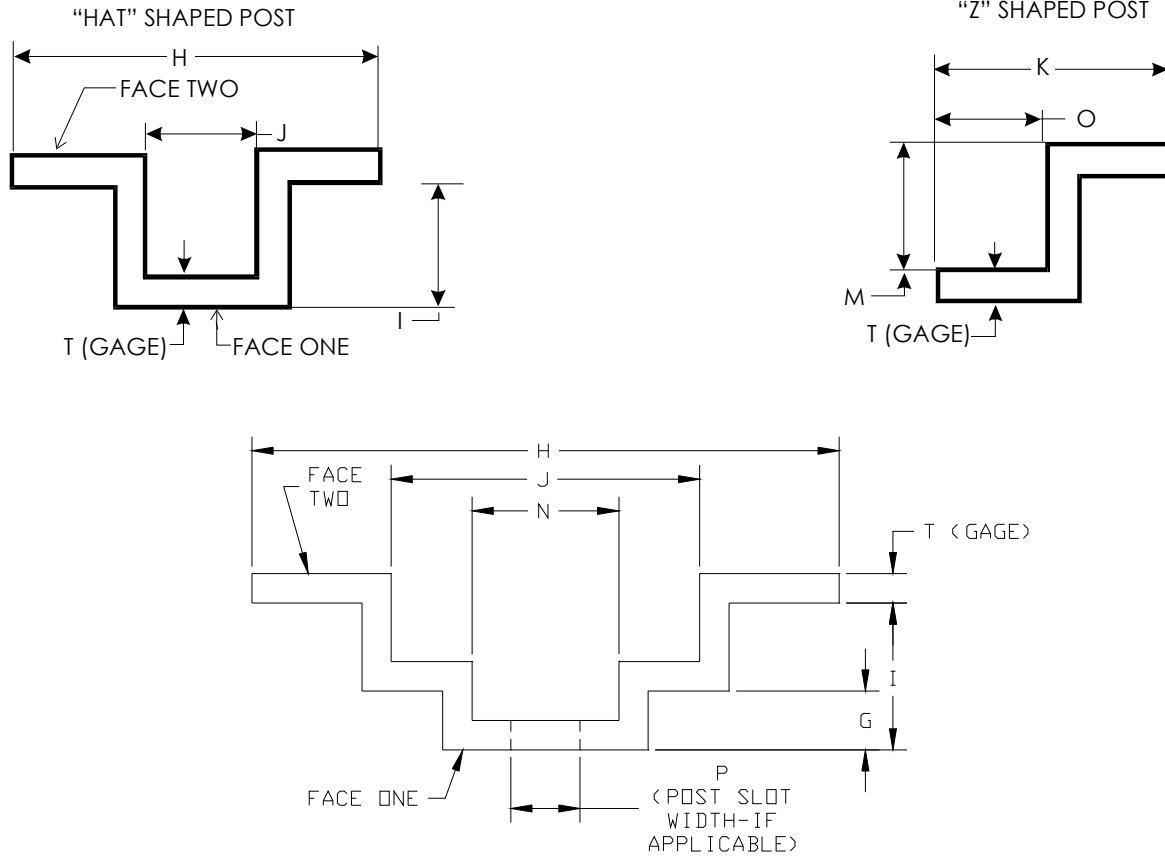

REAR POST MATERIAL: STEEL ALUMINUM

INTERIOR POST MATERIAL: STEEL ALUMINUM

IF "HAT" SHAPED POST IS SKIN AGAINST FACE: "ONE" "TWO"

H _____ I _____ J _____ T _____ K _____ M _____ O _____

N _____ P _____ G _____

CARGOMASTER INSTALLATION DATA QUESTIONNAIRE - Page 4 of 4

POWER CONNECTION Trailer to Tractor Wiring Options (Must Choose One)

- A. ____ 20-foot cable with quick connector socket at front trailer wall with alligator battery clips at tractor. (This option will be used if customer does not indicate a choice.)

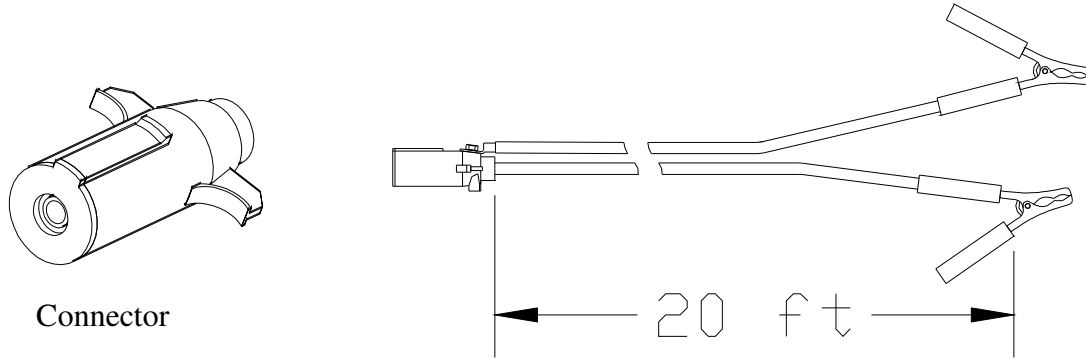

- B. ____ 10-foot cable with quick connector socket at front trailer wall with alligator battery clips at tractor.

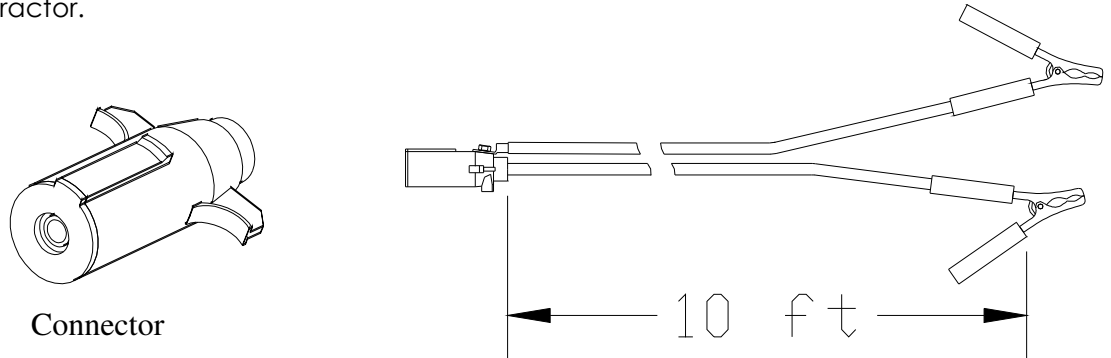

- C. ____ 20-foot cable with quick connector socket at front trailer wall with eyelet battery terminal at tractor.

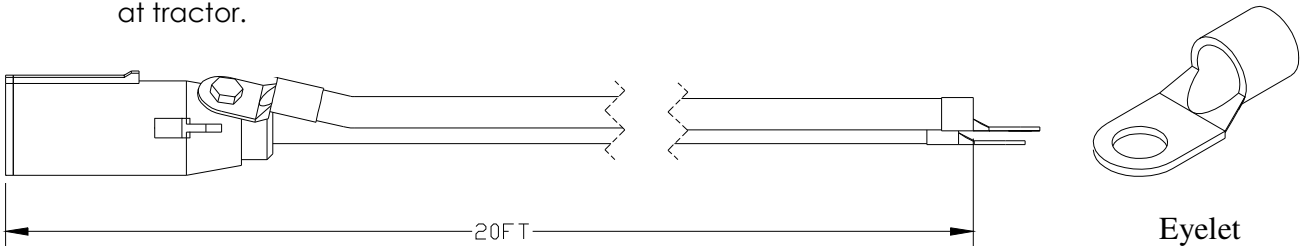

- D. ____ 10-foot cable with quick connector socket on both ends of cable.

